

SMART CONVEYOR MANUFACTURER



— SCAN | WEIGH | SORT | PALLETIZE —

[ailongsmart.com](http://ailongsmart.com)

# CATALOG

▫ <u>Conveyor series</u>	-----	3
1. <u>Belt conveyor</u>	-----	3
2. <u>Roller conveyor</u>	-----	5
3. <u>Chain conveyor</u>	-----	7
4. <u>Flexible conveyor</u>	-----	9
5. <u>Loading conveyor</u>	-----	10
6. <u>Telescopic conveyor</u>	-----	11
7. <u>Lifting conveyor</u>	-----	12
▫ <u>Solutions</u>	-----	13
1. <u>Scan &amp; weigh</u>	-----	13
2. <u>Sorting system</u>	-----	14
3. <u>Palletizing system</u>	-----	17
▫ <u>Custom products</u>	-----	18
▫ <u>Software products</u>	-----	19
▫ <u>Contact us</u>	-----	20

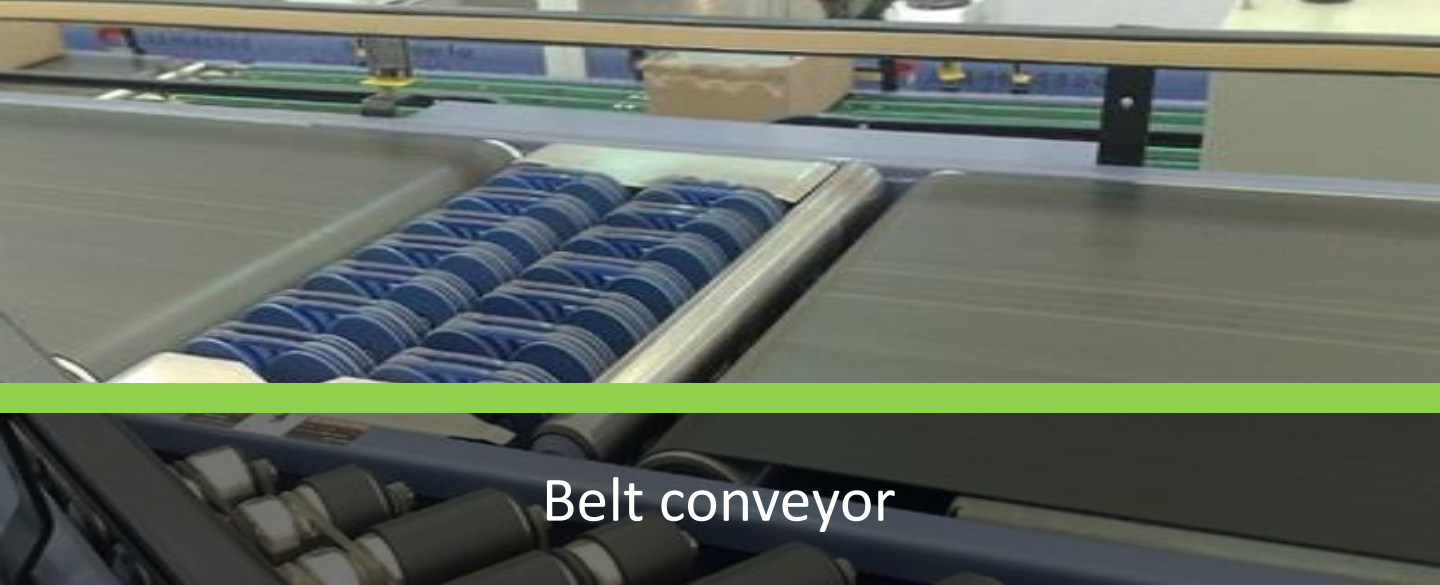

# Belt conveyor

The belt conveyor uses continuous and flexible flat belts to convey cartons and boxes. It can be selected to be driven by motor or electric roller. The friction force between the roller and the belt drives it forward.

## INTRODUCTION

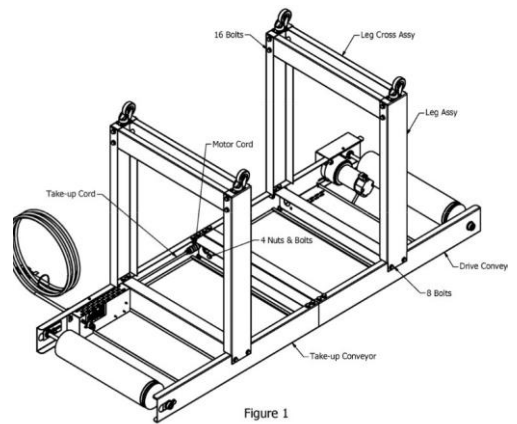
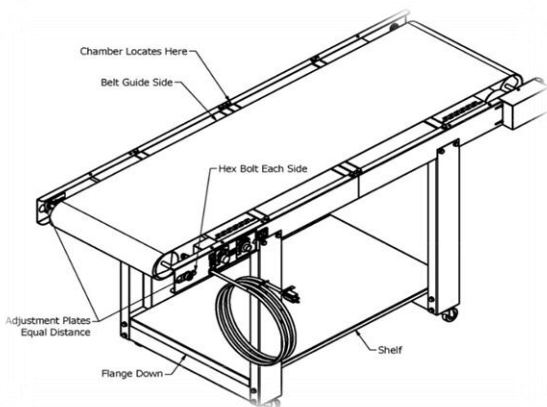
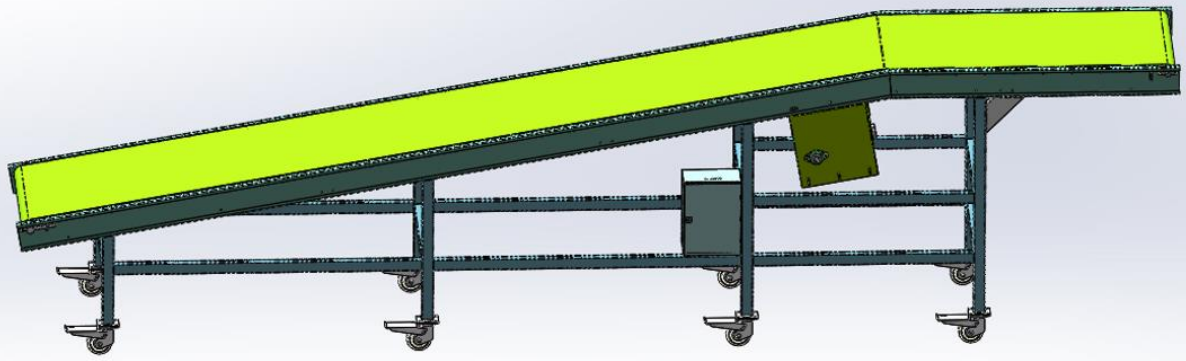

Figure 1

Flat belt conveyor

Load capacity:	0-100 kg/m	Motor brand:	SEW/CPG
Linear speed:	0-2 m/s adjustable	Control box:	Delta
Drive:	Motor / Electric roller	Belt material:	PVC/PU/rubber
Rated voltage:	Motor: 220/380 V Electric roller: 24 V	Body material:	Steel/stainless steel /aluminum profile
Rated power:	0.37-2.2 KW	Sensor brand:	Autonics



Inclined belt conveyor

Load capacity:	0-60 kg/m	Motor brand:	SEW/CPG
Linear speed:	0–1 m/s adjustable	Control box:	Delta
Drive:	Motor / Electric roller	Belt material:	Rubber
Rated voltage:	Motor: 220/380V Electric roller: 24V	Body material:	Steel/stainless steel
Rated power:	0.37-2.2 KW	Sensor brand:	Autonics

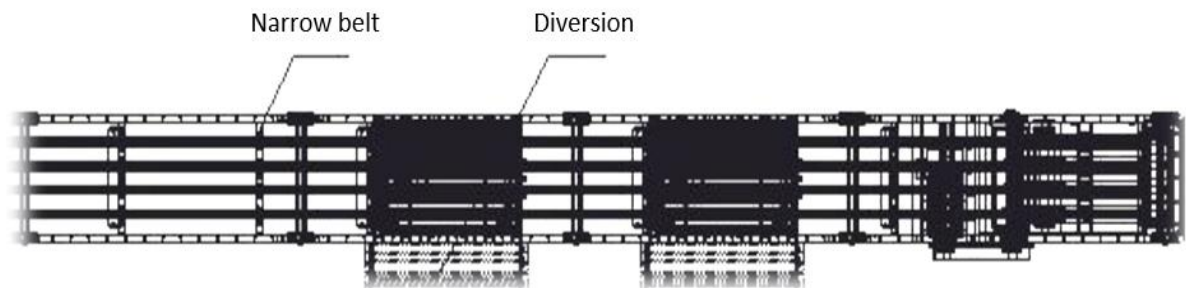

Narrow belt conveyor

Load capacity:	0-30 kg/m	Motor brand:	SEW/CPG
Linear speed:	0–1.5 m/s adjustable	Control box:	Delta
Drive:	Motor / Electric roller	Belt material:	PVC/PU
Rated voltage:	Motor: 220/380 V Electric roller: 24 V	Body material:	Steel/stainless steel
Rated power:	0.37-1.5 KW	Sensor brand:	Autonics



# Roller conveyor

The roller conveyor is composed of rollers, support legs and driving devices, etc. There are advantages such as large load capacity, fast speed, light operation and long life.

## INTRODUCTION

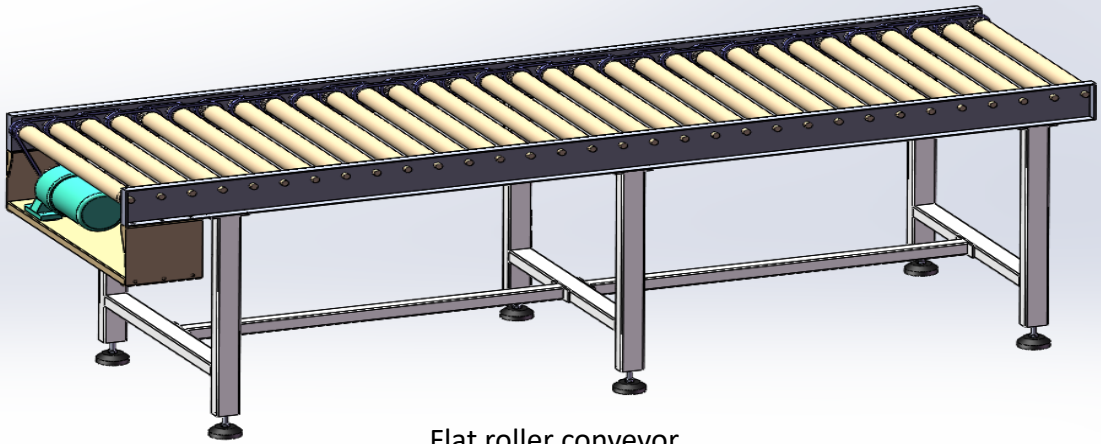

Flat roller conveyor

Load capacity:	0-1000 kg/m	Motor brand:	SEW/CPG
Linear speed:	0-2 m/s adjustable	Control box:	Delta
Drive:	Motor / Electric roller	Drive material:	Chain/poly-vee belt
Rated voltage:	Motor: 220/380 V Electric roller: 24 V	Body material:	Steel/stainless steel /aluminum profile
Rated power:	0.075-3.7 KW	Sensor brand:	Autonics

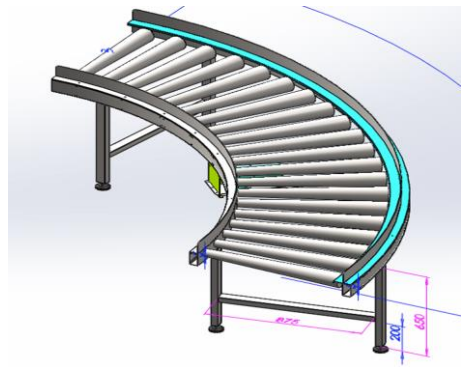
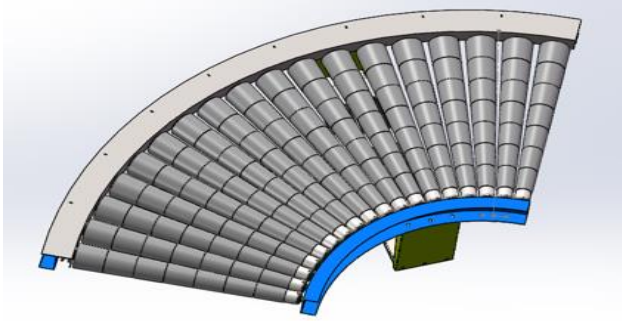

Curved roller conveyor

Load capacity:	0-500 kg/m	Motor brand:	SEW/CPG
Linear speed:	0–1 m/s adjustable	Control box:	Delta
Drive:	Motor / Electric roller	Drive material:	Chain/poly-vee belt
Rated voltage:	Motor: 220/380 V Electric roller: 24 V	Body material:	Steel/stainless steel /aluminum profile
Rated power:	0.075-3.7 KW	Sensor brand:	Autonics

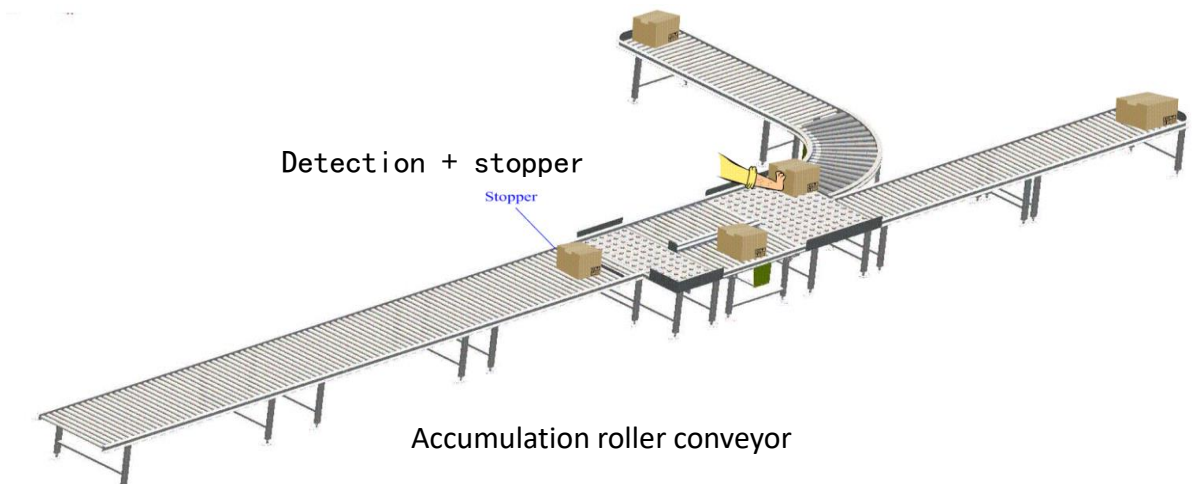

Accumulation roller conveyor

Load capacity:	0-1000 kg/m	Motor brand:	SEW/CPG
Linear speed:	0–1.5 m/s adjustable	Control box:	Delta
Drive:	Motor / Electric roller	Drive material:	Chain/poly-vee belt
Rated voltage:	Motor: 220/380 V Electric roller: 24 V	Body material:	Steel/stainless steel /aluminum profile
Rated power:	0.075-3.7 KW	Sensor brand:	Autonics



# Chain conveyor

The chain conveyor is mainly used to convey heavy goods carried by pallets, which can efficiently move, divert and buffer. The load of the whole system can reach up to 3t, and it can be easily running with speed 20m/min.

## INTRODUCTION

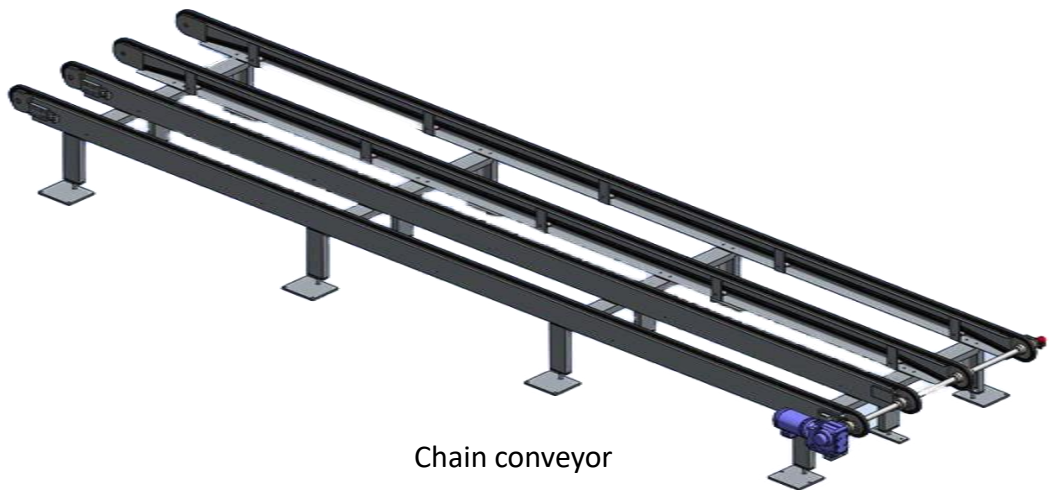

Chain conveyor

Load capacity:	0-3000 kg	Motor brand:	SEW/CPG
Linear speed:	0-0.5 m/s adjustable	Control box:	Delta
Drive:	Motor	Drive material:	Speed/duplex chain
Rated voltage:	220/380 V	Body material:	Steel/stainless steel
Rated power:	1.5-3.7 KW	Sensor brand:	Autonics

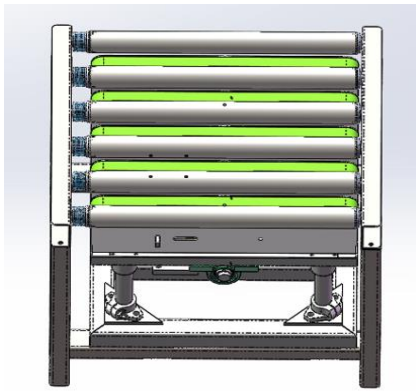

### Dimensions

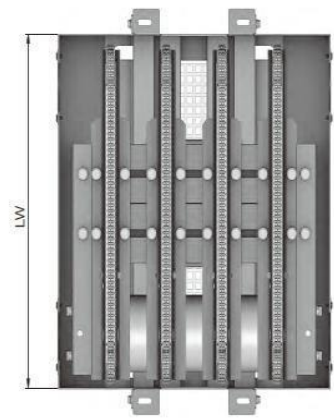
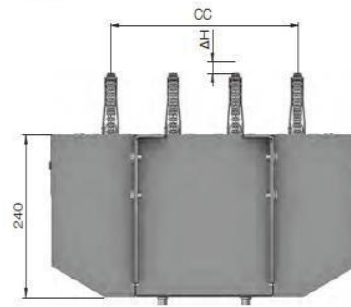

Lifting transfer conveyor

Load capacity:	0-500 kg	Motor brand:	SEW/CPG
Linear speed:	0.2-0.6 m/s adjustable	Control box:	Delta
Drive:	Motor	Drive material:	10/16B-1/2 chain
Rated voltage:	220/380 V	Body material:	Steel/stainless steel
Rated power:	0.1-1.5 KW	Sensor brand:	Autonics

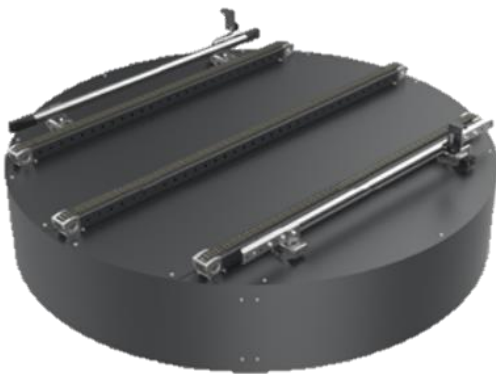

Rotating table

Load capacity:	0-500 kg	Motor brand:	SEW/CPG
Linear speed:	0.2-0.6 m/s adjustable	Control box:	Delta
Drive:	Motor	Drive material:	10/16B-1/2 chain
Rated voltage:	220/380 V	Body material:	Steel/stainless steel /aluminum profile
Rated power:	0.1-1.5 KW	Sensor brand:	Autonics





# Flexible conveyor

The flexible conveyor is usually used for loading and unloading in workshops and warehouses. It can also be applied to ship or receive in packing/conveyor lines. There is manual or electric type.

## INTRODUCTION

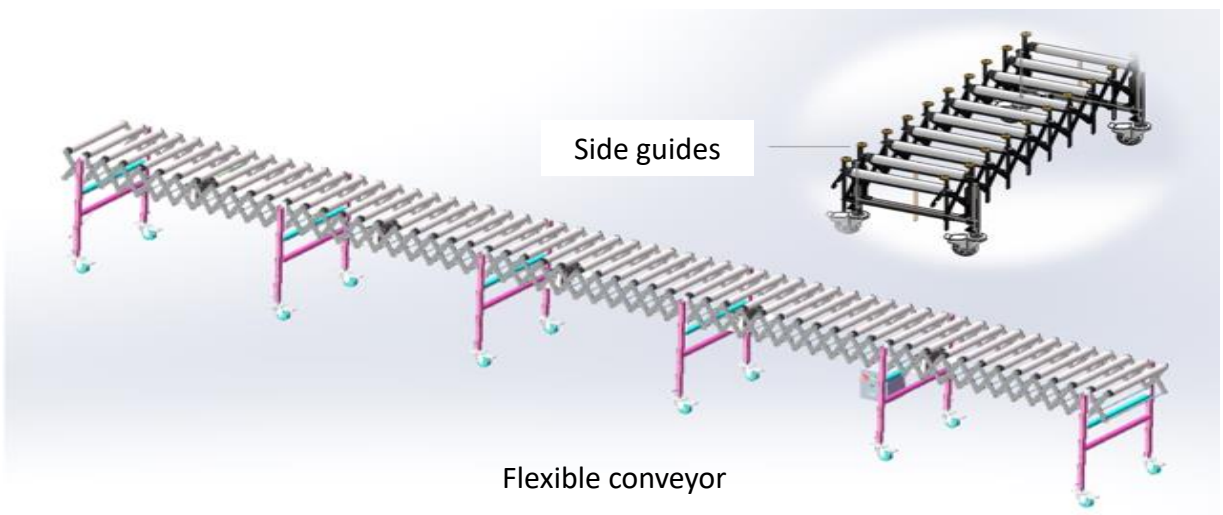

Flexible conveyor

Load capacity:	0-100 kg	Motor brand:	SEW/CPG
Linear speed:	0-1.5 m/s adjustable	Control box:	Delta
Drive:	Motor / Electric roller	Drive material:	Poly-vee belt
Rated voltage:	Motor: 220/380 V Electric roller: 24 V	Body material:	Steel/stainless steel
Rated power:	75-120 W	Sensor brand:	Autonics



# Loading conveyor

The loading belt conveyor and the flexible conveyor are usually used in combination. There are advantages such as high sorting capacity, which can be max.15,000 pcs/h.

## INTRODUCTION

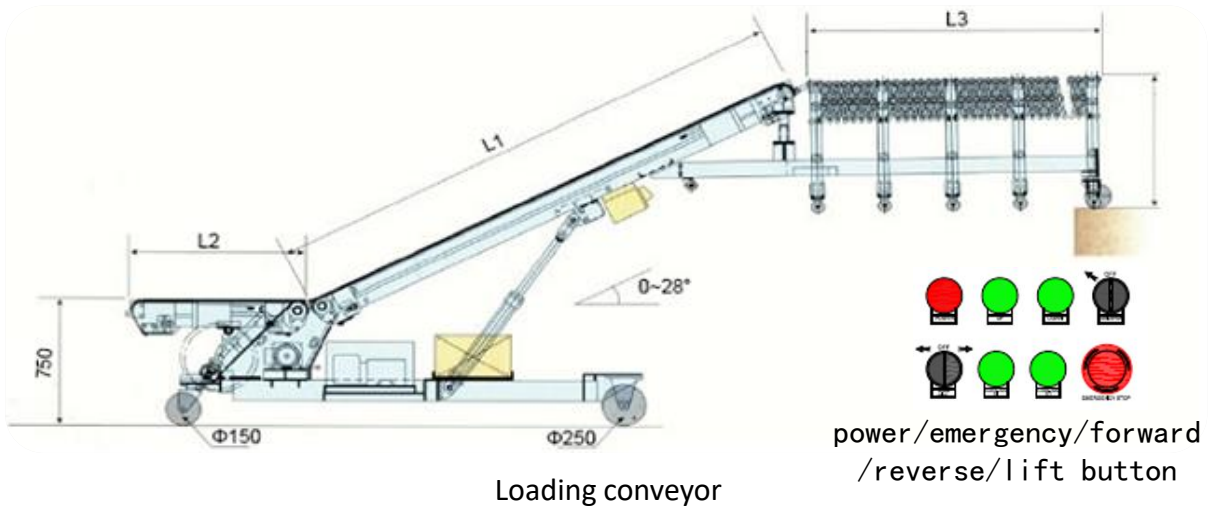

Load capacity:	0-100 kg	Motor brand:	SEW/CPG
Linear speed:	0-1.5 m/s adjustable	Control box:	Delta
Drive:	Motor	Drive material:	Hydraulic type
Rated voltage:	220/380 V	Body material:	Steel/stainless steel
Rated power:	1.5-2.2 KW	Sensor brand:	Autonics



## Telescopic conveyor

The total length of the telescopic conveyor can reach up to 28m. The telescopic section is equipped with safety devices such as lighting, anti-collision, and emergency stop. Suitable for conveying goods of any shape.

### INTRODUCTION

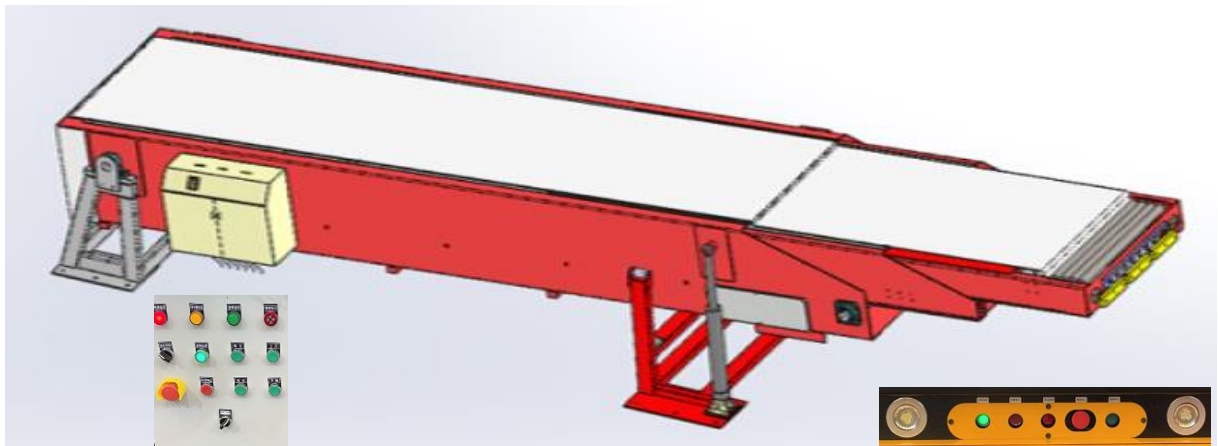

Telescopic conveyor

Load capacity:	0-60 kg/m	Motor brand:	SEW/CPG
Linear speed:	0-1 m/s adjustable	Control box:	Delta
Drive:	Motor	Drive material:	Height: hydraulic type
Rated voltage:	220/380 V	Body material:	Steel/stainless steel
Rated power:	1.1-2.2 KW	Sensor brand:	Autonics

# Lifting conveyor

The lifting conveyor is suitable for operations between multiple floors. It is widely used in distribution centers, warehouses, and factories. There are advantages such as fast safety door, anomaly detection and other safety design.

## INTRODUCTION

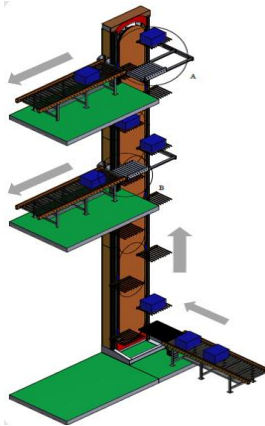
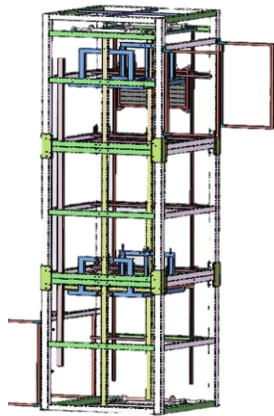

Lifting conveyor

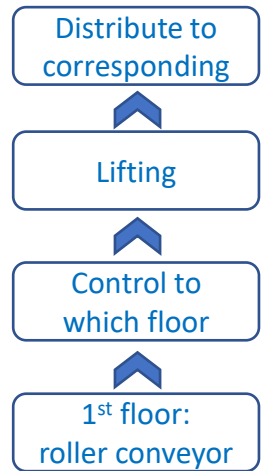

Load capacity:	0-60 kg/m	Motor brand:	SEW/CPG
Linear speed:	0-1 m/s adjustable	Control box:	Delta
Drive:	Motor	Drive material:	Reciprocating / Continuous
Rated voltage:	220/380 V	Body material:	Steel/stainless steel
Rated power:	1.1-3.7 KW	Sensor brand:	Autonics



## Scanning & weighing system

### INTRODUCTION



- ▣ Scan, measure volume and weight, upload
- ▣ Industrial/smart camera, accuracy 99.99%
- ▣ Dynamic weighing, accuracy up to 10g
- ▣ Integration with other systems

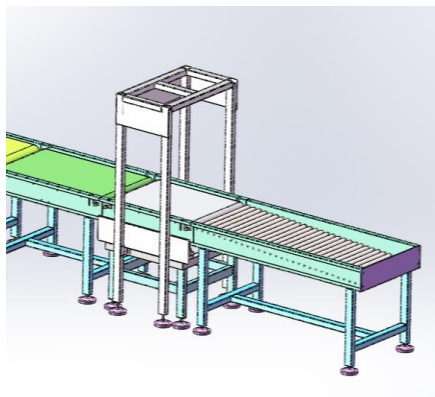

Scanning efficiency	Max.10000 pcs/h
Measurement	Max.100 kg
Conveying speed	0-2 m/s
Software kit	Scan and monitor platform
Protocol	HTTP/API, etc.

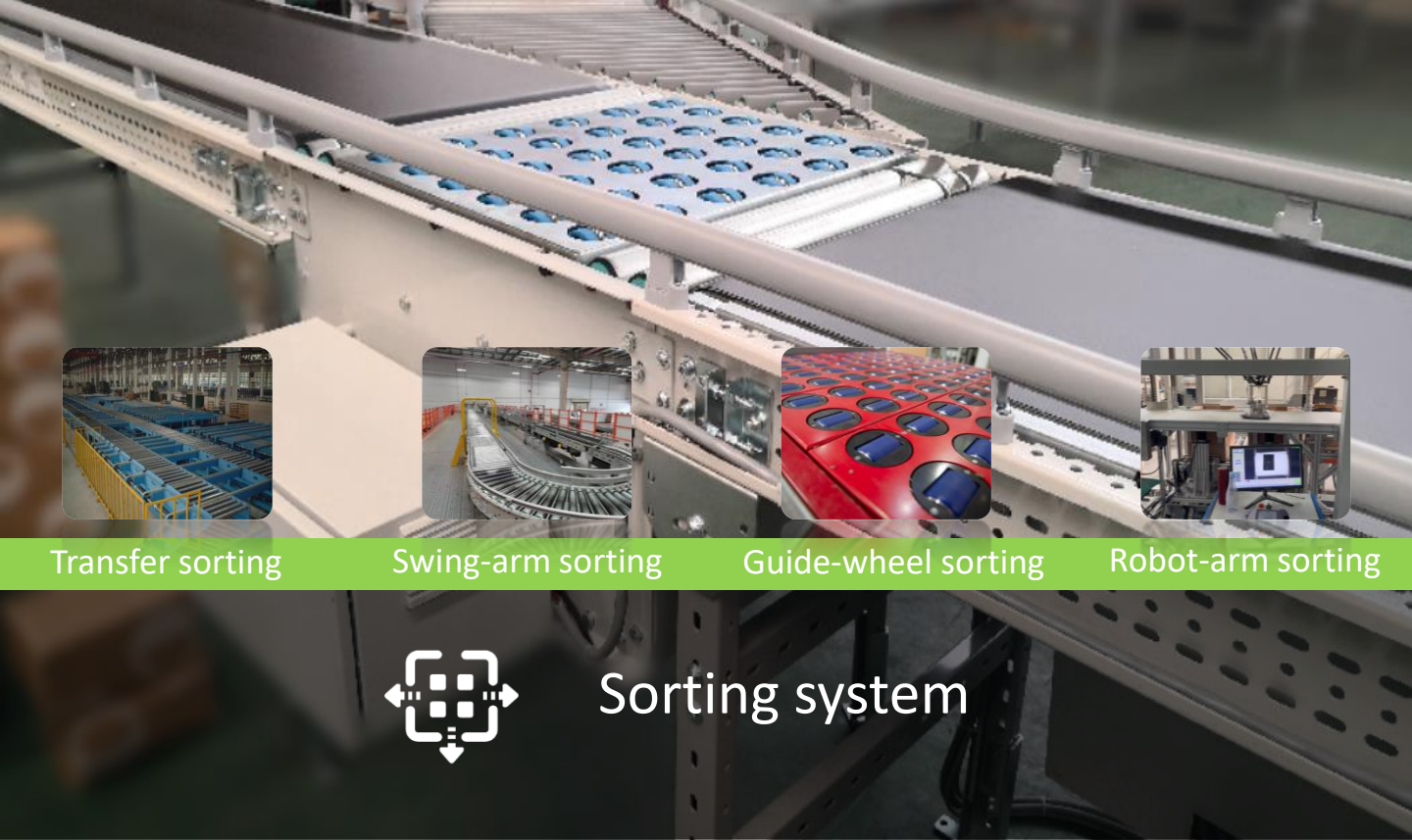

Transfer sorting

Swing-arm sorting

Guide-wheel sorting

Robot-arm sorting



## Sorting system

### Transfer sorting



- ▣ Lift & transfer for heavy goods
- ▣ Convey cartons, boxes and flat bottom goods
- ▣ Driven by motor / electric roller
- ▣ PLC/Industrial control/Software control

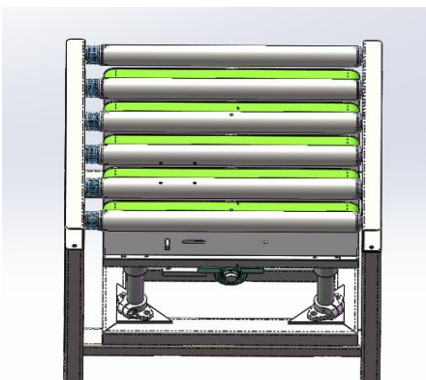

Weight range	Max.3000 kg
Rotating speed	0.2 - 0.3 m/s
Rotating angle	90°
Goods dimension	Max.L2500xW1400mm Min.L250xW250mm

## Swing-arm sorting



- ▣ Push goods to the corresponding position through the swing arm
- ▣ Convey all kinds of irregular goods
- ▣ Simple structure, but high accuracy
- ▣ PLC/Industrial control/Software control

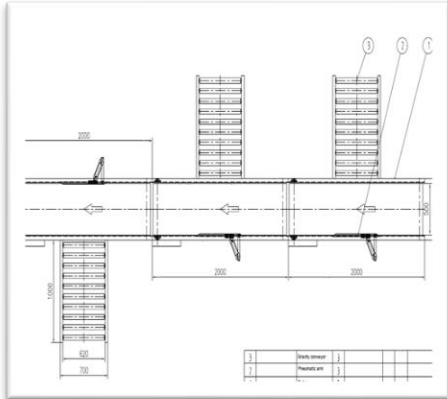

Weight range	Max.30 kg
Sorting efficiency	3000 pcs/h(single arm)
Swing speed	≤1 s
Goods dimension	Max. L1500xW800mm Min. L150xW150mm

## Guide-wheel sorting



- ▣ Multi-directional diversion by guide wheels
- ▣ Convey clothes, books and flat bottom goods
- ▣ Easy for maintenance by monitoring the running status
- ▣ PLC/Industrial control/Software control

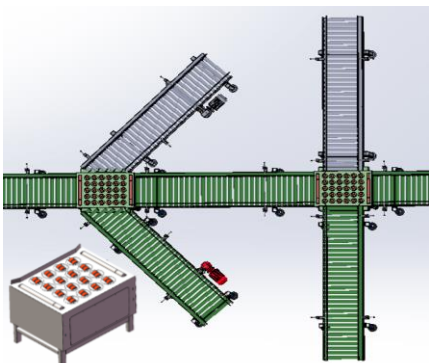

Weight range	Max.100 kg
Sorting efficiency	Max.8000 pcs/h
Rotating speed	1.8 - 2.5 m/s
Goods dimension	Max.L1400xW1400mm Min.L100xW100mm

## Robot-arm sorting

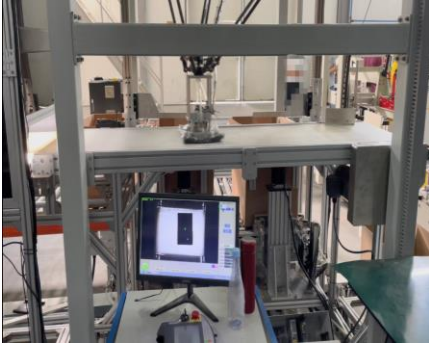

- The software will control robot arms
- Convey clothes, books and flat bottom goods
- High accuracy for complex application scenarios
- PLC/Industrial control/Software control

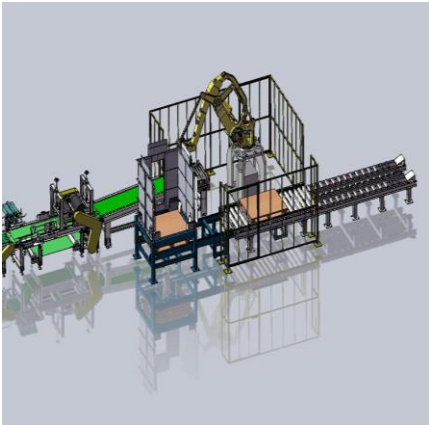

Weight range	Max.1000 kg
Sorting efficiency	1600 pcs/h
Control method	By color, volume, weight, barcode, etc.
Goods dimension	Max.L1400xW1400xH1400mm Min.L100xW50xH50mm

## Implementation



- Research requirements and systems [report]
- Make mechanical solution [drawing]
- Make software solution [prototype]



- Product and program [finished products]
- Test internally [testing report]
- Operate on-site [delivery]



- ★ Free maintenance in one year
- ★ Free software upgrading support
- ★ Free consulting for business/data analysis





## Palletizing system

### INTRODUCTION



- ▣ Palletizing by scanning or sensing
- ▣ Convey cartons/bottles/bags/buckets, etc.
- ▣ Sorting-loading-handling after production
- ▣ PLC/Industrial control/Software control



Palletizing efficiency	Max.850 pcs/h
Calibration method	Automatic
Protocol	Ethernet
Compatible robot	YASKAWA, ABB, KUKA, etc.



**Bao Steel**  
Heavy-duty centering equipment



**Huineng New Material**  
Positioning and packaging system



**Beinuo Wind Machinery**  
Custom palletizing system

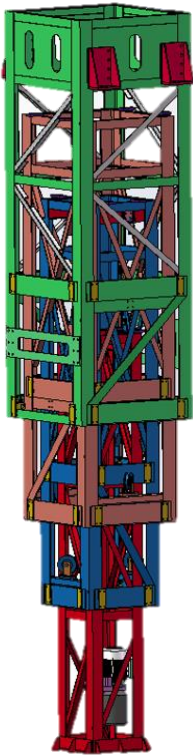
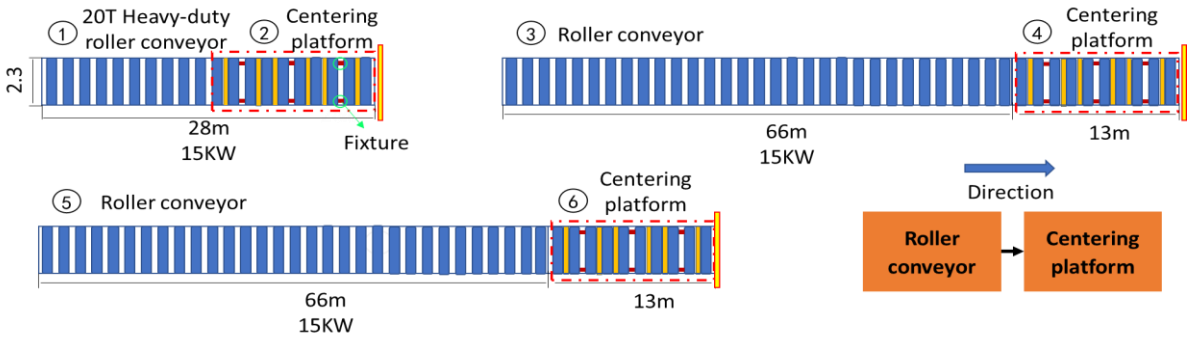

Telescopic equipment for crane

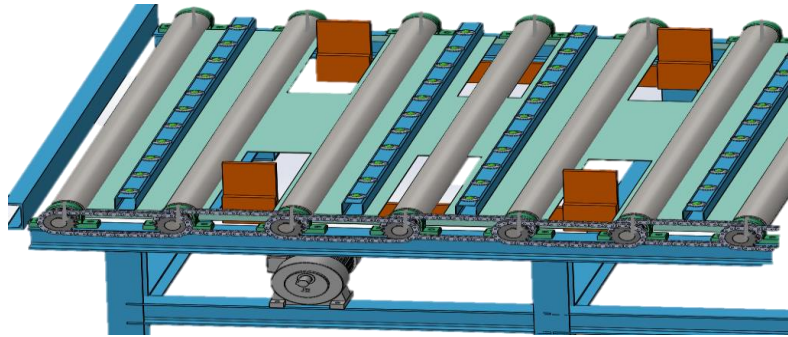

Centering conveyor

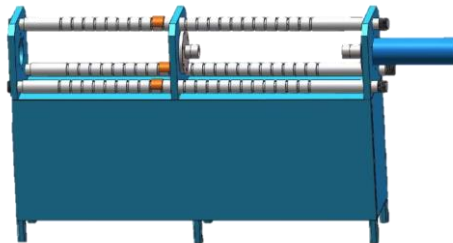

Roller manufacturing machine

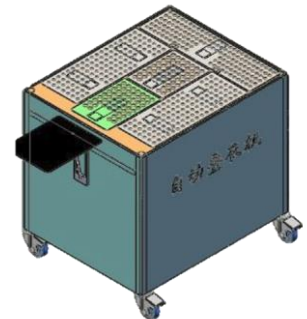

Automatic clothes-folding machine



Make data more valuable

Software solution



## Structure

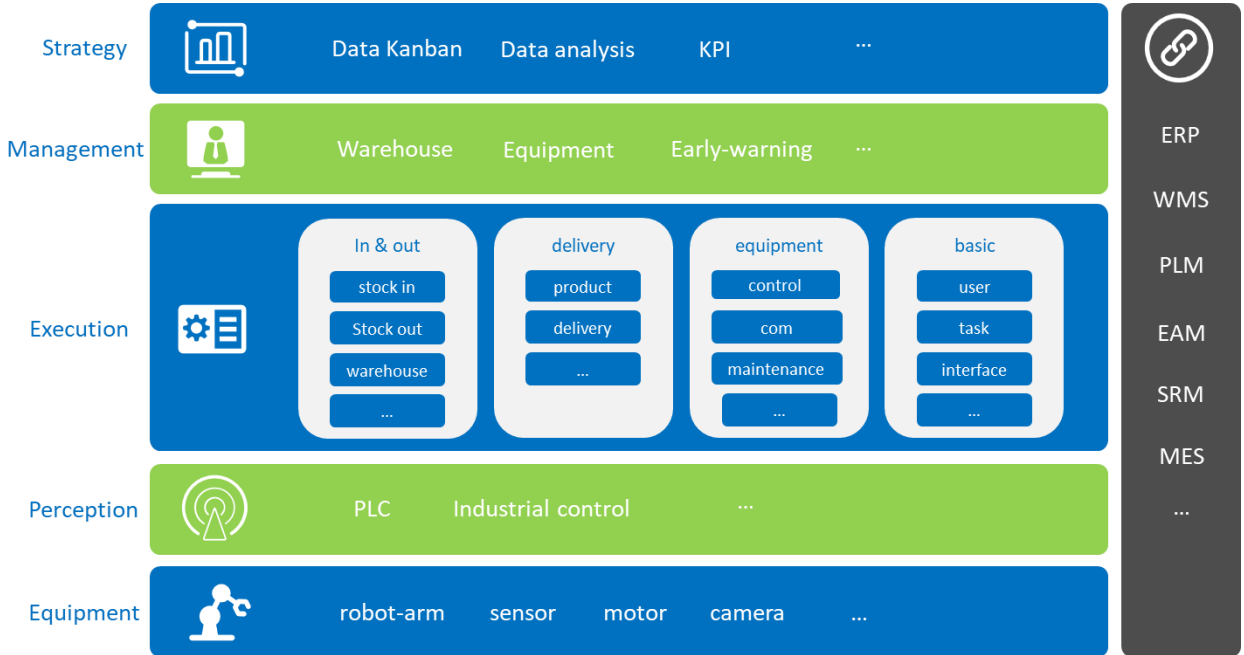

## Example

**Inventory Management**

- 拣货
- 复核
- 打包
- 拆分包裹发货
- 称重
  - 称重
  - 批量称重
  - 车号称重
  - 整箱称重
- 复核打包称重
- 交接
- 出库拦截
- 物流单登记
- 波次单完成扫描
- 线下出库
- 取消过库
- 强制缺货订单
- 赠品会订单导入
- 拣货打单
- 拣货完成扫描
- 发货
- 库存管理
- 计费管理
- 查询中心
- 财务报表
- 入库报表
- 出库报表
- 库存报表
- 综合报表

**Form Fields:**

- 是否记录转材
- 先称重
- 箱型
- 包裹单号
- 标准重量(kg)
- 重量
- 信息

**Data Table:**

Information	Time	Material ID	Status	Weight
称重完成	2021-11-22 14:47:04	[SF1319324066141]	称重完成 (575)	
包裹单号	2021-11-22 14:47:03	[SF1319324066141]	属于拆分包裹单据 (574)	
称重完成	2021-11-22 14:47:01	[SF2040811125771]	称重完成 (573)	
包裹单号	2021-11-22 14:47:00	[SF2040811125771]	属于拆分包裹单据 (572)	
称重完成	2021-11-22 14:46:56	[SF1325803646635]	称重完成 (571)	
包裹单号	2021-11-22 14:46:57	[SF1308956294046]	属于拆分包裹单据 (569)	
称重完成	2021-11-22 14:46:57	[SF1308956294046]	称重完成 (570)	
包裹单号	2021-11-22 14:46:57	[SF1308956294046]	属于拆分包裹单据 (568)	
称重完成	2021-11-22 14:46:57	[SF2007192692359]	称重完成 (568)	
包裹单号	2021-11-22 14:46:57	[SF2007192692359]	属于拆分包裹单据 (567)	
称重完成	2021-11-22 14:46:57	[SF204036444]	称重完成 (566)	
包裹单号	2021-11-22 14:46:57	[SF204036444]	属于拆分包裹单据 (567)	
称重完成	2021-11-22 14:46:57	[SF184118535]	称重完成 (565)	
包裹单号	2021-11-22 14:46:57	[SF184118535]	属于拆分包裹单据 (566)	
称重完成	2021-11-22 09:59:54	[SF2010819705019]	称重完成 (564)	
包裹单号	2021-11-22 09:59:54	[SF2010819705019]	属于拆分包裹单据 (563)	
称重完成	2021-11-22 09:59:53	[SF2010819705019]	称重完成 (563)	
包裹单号	2021-11-22 09:59:53	[SF2010819705019]	属于拆分包裹单据 (561)	

**Function Icons:**

- Scanning (Icon: Scanner)
- Volume & weight (Icon: Scale)
- Sorting control (Icon: Sorting machine)
- Data synchronization (Icon: Refresh)



AI-LONG



## Cooperation



**Ningbo Ailong Smart Technology Co Ltd**



No. 427 H2 Building Qinglin Business Center, Ningbo 315000, China



No. 102 Building 16 Licheng Intelligent Manufacturing Industrial Park  
North District, Huzhou 313000, China



+86 18767223029



bertramxu@ailongsmart.com

Visit our website for more information

[ailongsmart.com](http://ailongsmart.com)

[www.mctsmart.com](http://www.mctsmart.com)

